

## FOCUS-1512-120D

### Single-mode SFP Transceiver

### 120Km Transmission with

### Internally-calibrated DDM

#### Feature

- Compliant with SFP Transceiver SFF-8472 MSA specification with internal calibration
- Compliant with proposed specifications for IEEE 802.3z/Gigabit Ethernet
- Compliant with Industry Standard RFT Electrical Connector and Cage
- 100% differential AC coupled CML Outputs
- Single + 3.3V Power Supply and TTL Logic Interface
- Up to 1.25Gb/s bi-directional data link
- 1550nm Uncooled DFB Laser Transmitter
- APD Receiver
- Up to 120km transmission distance
- Hot Pluggable
- Duplex LC Connector interface
- Metal enclosure, for Lower EMI
- Class 1 Laser Product Compliant with the Requirements of IEC 60825-1 and IEC 60825-2

#### Applications

- ◆ Gigabit Ethernet
- ◆ Fibre channel
- ◆ Switch to Switch interface
- ◆ Switched backplane applications
- ◆ File server interface

#### Description

The FOCUS-1512-120D pluggable transceiver module is a high performance integrated duplex data link for bi-directional communication over single mode optical fiber. It is compliant with the MSA Small Form Factor Pluggable (SFP) specification. The transceiver can support GbE (1.25Gb/s) as well as 1x Fiber channel (1.062Gb/s) operations.

The FOCUS- 1512-120D series are designed to be compliant with SFF-8472 SFP Multi-source Agreement (MSA).

#### Absolute Maximum Ratings

Parameter	Symbol	Min.	Max.	Unit
Storage Temperature	T <sub>S</sub>	-40	+85	°C
Supply Voltage	V <sub>CC</sub>	-0.5	3.6	V

**Recommended Operating Conditions**

Parameter	Symbol	Min.	Typical	Max.	Unit
Operating Ambient Temperature	$T_A$	0		+70	°C
Power Supply Voltage	$V_{CC}$	3.15	3.3	3.45	V
Power Supply Current	$I_{CC}$			300	mA
Surge Current	$I_{Surge}$			+30	mA

**PERFORMANCE SPECIFICATIONS - ELECTRICAL**

0°C&lt;Tc&lt;+80°C; +3.15V&lt;Vcc&lt;+3.6V

Parameter	Symbol	Min.	Typ.	Max.	Unit	Notes
<b>TRANSMITTER</b>						
CML/PECL Inputs (Differential)	$V_{in}$	400		2500	mVpp	AC coupled inputs
Input Impedance (Differential)	$Z_{in}$	85	100	115	ohms	$R_{in} > 100 \text{ kohms @ DC}$
Tx_DISABLE Input Voltage - High		2		3.45	V	
Tx_DISABLE Input Voltage - Low		0		0.8	V	
Tx_FAULT Output Voltage -- High		$V_{cc}-0.5$		$V_{cc}+0.3$	V	$I_o = 400\mu \text{ A; Host } V_{cc}$
Tx_FAULT Output Voltage -- Low		0		0.5	V	$I_o = -4.0\text{mA}$
<b>RECEIVER</b>						
CML Outputs (Differential)	$V_{out}$	400	800	1200	mVpp	AC coupled outputs
Output Impedance (Differential)	$Z_{out}$	85	100	115	ohms	
Rx_LOS Output Voltage - High		$V_{cc}-0.5$		$V_{cc}+0.3$	V	$I_o = 400\mu \text{ A; Host } V_{cc}$
Rx_LOS Output Voltage - Low		0		0.8	V	$I_o = -4.0\text{mA}$
Total Jitter [ Pk - Pk ]	TJ			130	ps	Measured with 27 - 1 PRBS@4.25Gbps
MOD_DEF ( 0:2 )	VoH	2.5			V	With Serial ID
	VoL	0		0.5	V	

**OPTICAL SPECIFICATIONS**

0°C&lt;Tc&lt;+80°C; +3.15V&lt;Vcc&lt;+3.6V

Parameter	Symbol	Min.	Typ.	Max	Unit	Notes
9μm Core Diameter SMF				100	Km	BER<1.0E-12@1.25/1.0625GBaud

TRANSMITTER						
Optical Center Wavelength	$\lambda$	1530	1550	1570	nm	
Spectral Width	$\Delta\lambda$			1	nm	RMS
Optical Transmit Power	Po	0		5	dBm	Average @850nm
Side Mode Suppression Ratio	SMSR	40	30		dB	
Extinction Ratio @1.25Gbps	ER	9			dB	P1/P0
Total Jitter	TJ			170	ps	Measured with 2 <sup>7</sup> - 1 PRBS@4.25Gbps
Output Rise/Fall Time	tR, tF			0.4	ns	20-80%; measured @ 4.25GBaud
RECEIVER						
Optical Input Wavelength	$\lambda$	1100		1650	nm	
Receiver Sensitivity				-30	dBm	
Optical Return Loss	ORL	12			dB	
RX_LOS Asserted	Pa	-29			dBm	Measured on transition - Low to High
RX_LOS Deasserted	Pd			-17	dBm	Measured on transition - High to Low

### SFP Transceiver Electrical Pad Layout

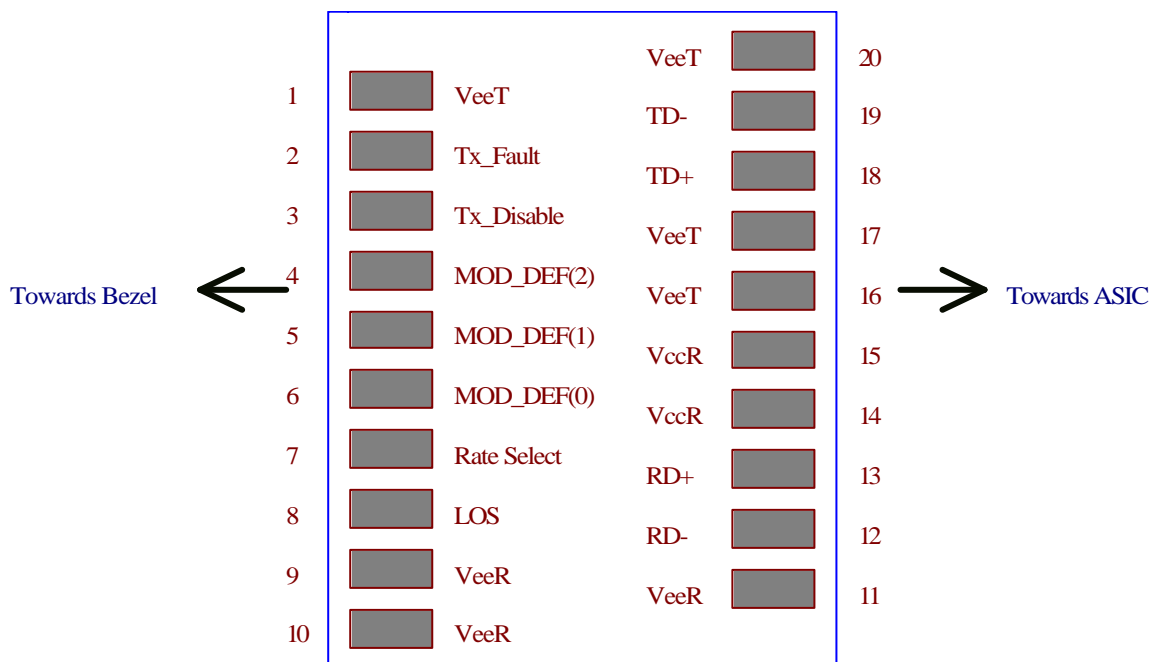

## Pin Function Definitions

Pin Num.	Name	FUNCTION	Plug Seq.	Notes
1	VeeT	Transmitter Ground	1	
2	TX Fault	Transmitter Fault Indication	3	Note 1
3	TX Disable	Transmitter Disable	3	Note 2, Module disables on high or open
4	MOD-DEF2	Module Definition 2	3	Note 3, 2 wire serial ID interface
5	MOD-DEF1	Module Definition 1	3	Note 3, 2 wire serial ID interface
6	MOD-DEF0	Module Definition 0	3	Note 3, 2 wire serial ID interface
7	Rate Select	Not Connect	3	Function not available
8	LOS	Loss of Signal	3	Note 4
9	VeeR	Receiver Ground	1	Note 5
10	VeeR	Receiver Ground	1	Note 5
11	VeeR	Receiver Ground	1	Note 5
12	RD-	Inv. Received Data Out	3	Note 6
13	RD+	Received Data Out	3	Note 7
14	VeeR	Receiver Ground	1	Note 5
15	VccR	Receiver Power	2	3.3 ± 5%, Note 7
16	VccT	Transmitter Power	2	3.3 ± 5%, Note 7
17	VeeT	Transmitter Ground	1	Note 5
18	TD+	Transmit Data In	3	Note 8
19	TD-	Inv. Transmit Data In	3	Note 8
20	VeeT	Transmitter Ground	1	Note 5

### Notes:

1) TX Fault is an open collector/drain output, which should be pulled up with a 4.7K – 10K $\Omega$  resistor on the host board. Pull up voltage between 2.0V and VccT, R+0.3V. When high, output indicates a laser fault of some kind. Low indicates normal operation. In the low state, the output will be pulled to < 0.8V.

2) TX disable is an input that is used to shut down the transmitter optical output. It is pulled up within the module with a 4.7 – 10 K $\Omega$  resistor. Its states are:

Low (0 – 0.8V): Transmitter on

(>0.8, < 2.0V): Undefined

High (2.0 – 3.465V): Transmitter Disabled

Open: Transmitter Disabled

3) Mod-Def 0,1,2. These are the module definition pins. They should be pulled up with a 4.7K – 10K $\Omega$  resistor on the host board. The pull-up voltage shall be VccT or VccR (see Section IV for further details). Mod-Def 0 is grounded by the module to indicate that the module is present. Mod-Def 1 is the clock line of two wire serial interface for serial ID. Mod-Def 2 is the data line of two wire serial interface for serial ID.

4) LOS (Loss of Signal) is an open collector/drain output, which should be pulled up with a 4.7K – 10K $\Omega$  resistor. Pull up voltage between 2.0V and VccT, R+0.3V. When high, this output indicates the received optical power is below the worst-case receiver sensitivity (as defined by the standard in use). Low indicates normal operation. In the low state, the output will be pulled to < 0.8V.

5) VeeR and VeeT may be internally connected within the SFP module.

6) RD-/+ : These are the differential receiver outputs. They are AC coupled 100 $\Omega$  differential lines which should be terminated with 100 $\Omega$  (differential) at the user SERDES. The AC coupling is done inside the module and is thus not required on the host board. The voltage swing on these lines will be between 370 and 2000 mV differential (185–1000 mV single ended) when properly terminated.

7) VccR and VccT are the receiver and transmitter power supplies. They are defined as 3.3V  $\pm$  5% at the SFP connector pin. Maximum supply current is 300mA. Recommended host board power supply filtering is shown below. Inductors with DC resistance of less than 1 ohm should be used in order to maintain the required voltage at the SFP input pin with 3.3V supply voltage. When the recommended supply-filtering network is used, hot plugging of the SFP transceiver module will result in an inrush current of no more than 30mA greater than the steady state value. VccR and VccT may be internally connected within the SFP transceiver module.

8) TD-/+ : These are the differential transmitter inputs. They are AC-coupled, differential lines with 100 $\Omega$  differential termination inside the module. The AC coupling is done inside the module and is thus not required on the host board. The inputs will accept differential swings of 500 – 2400 mV (250 – 1200mV single-ended), though it is recommended that values between 500 and 1200 mV differential (250 – 600mV single-ended) be used for best EMI performance.

## Recommend Circuit Schematic

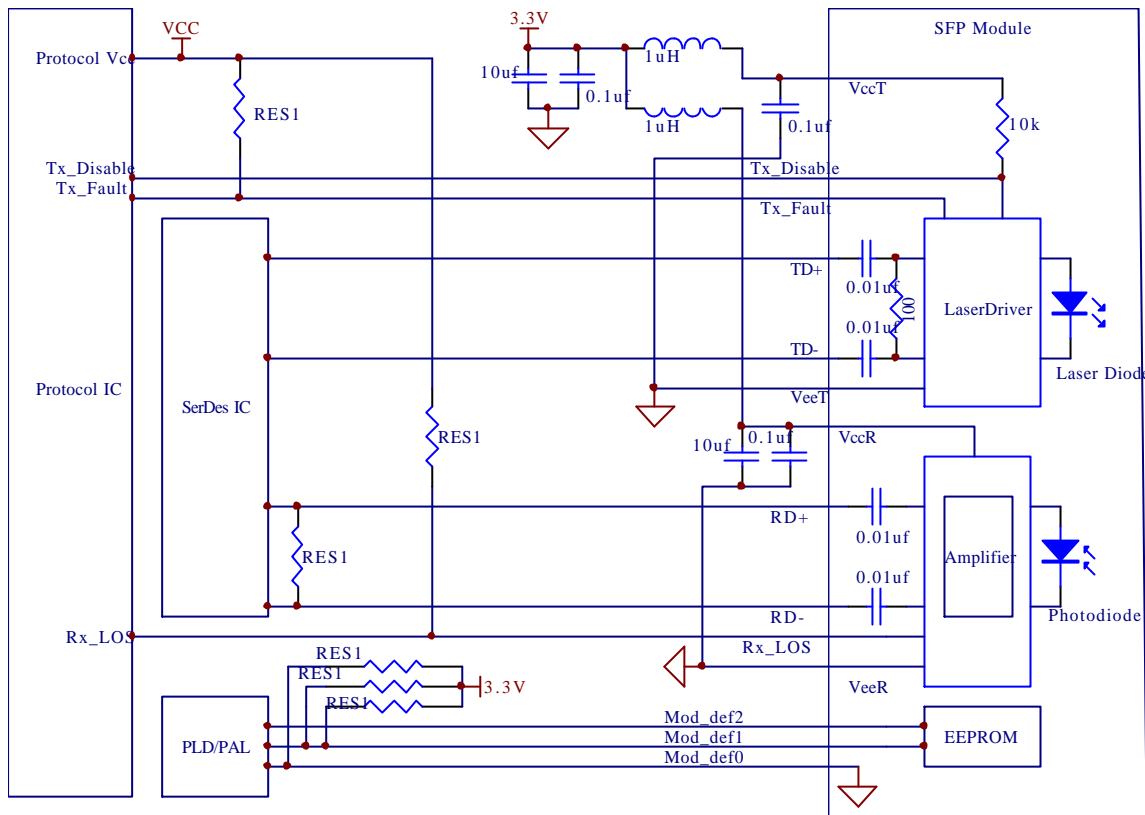

RES1 = 4.7k to 10k

## DIGITAL DIAGNOSTIC MONITORING INTERFACE

Eoptolink SFP transceivers support the 2-wire serial communication protocol as defined in the SFP Multi-Source Agreement (MSA). The FOCUS-1512-120D SFP transceivers are provided with enhanced digital diagnostic monitoring interface (DDMI) which allows real-time access to device operating parameters such as transceiver temperature, laser bias current, transmitted optical power, received optical power and transceiver supply voltage. It also defines a system of alarm flags, which alerts end-users when particular operating parameters are outside of a factory set normal range. The SFP is fully compliant to the SFF-8472 Rev. 9.3 specification.

The SFP MSA defines a 256-byte memory map in EEPROM that is accessible over a 2-wire serial interface at the 8-bit address 1010000X (A0h). The digital diagnostic monitoring interface makes use of the 8-bit address 1010001X (A2h), so the originally defined serial ID memory map remains unchanged. The interface is identical to and is thus fully backward compatible with the SFP Multi-Source Agreement.

Eoptolink SFP with DDMI are externally calibrated (bit 4 is set at address 92) which means that the measurements are raw A/D values and must be converted to real world units using calibration constants stored in the EEPROM location 56-95 at 2-wire serial bus address A2h.

For detailed interface information, please refer to SFF-8472 rev. 9.3 specification.

### Mechanical Specifications

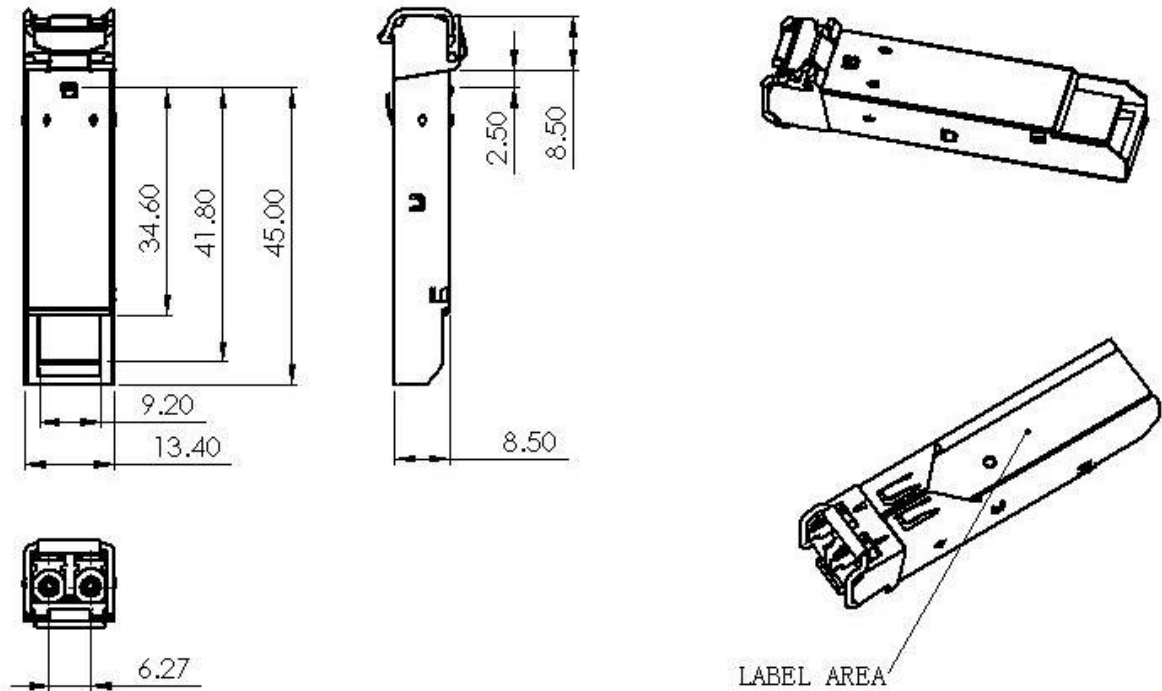

DIMENSIONS IN MILLIMETERS

### Ordering information

Part No.	Data Rate	Laser	Fiber Type	Distance	Optical interface
FOCUS-1512-120D	1.0625/1.25Gbps with digital diagnostic	1550nm DFB	SMF	100Km	LC